

NEW!

Spring-loaded stuffing box

For process pumps in ammonia (NH₃) service

In the course of continuous product optimization URACA developed a new stuffing box.

This new and improved design you can get in all our pumps of the KD 600, KD 700 and KD 800 series as well as in the Px-70, Px-80, Px-96 and Px-98 series.

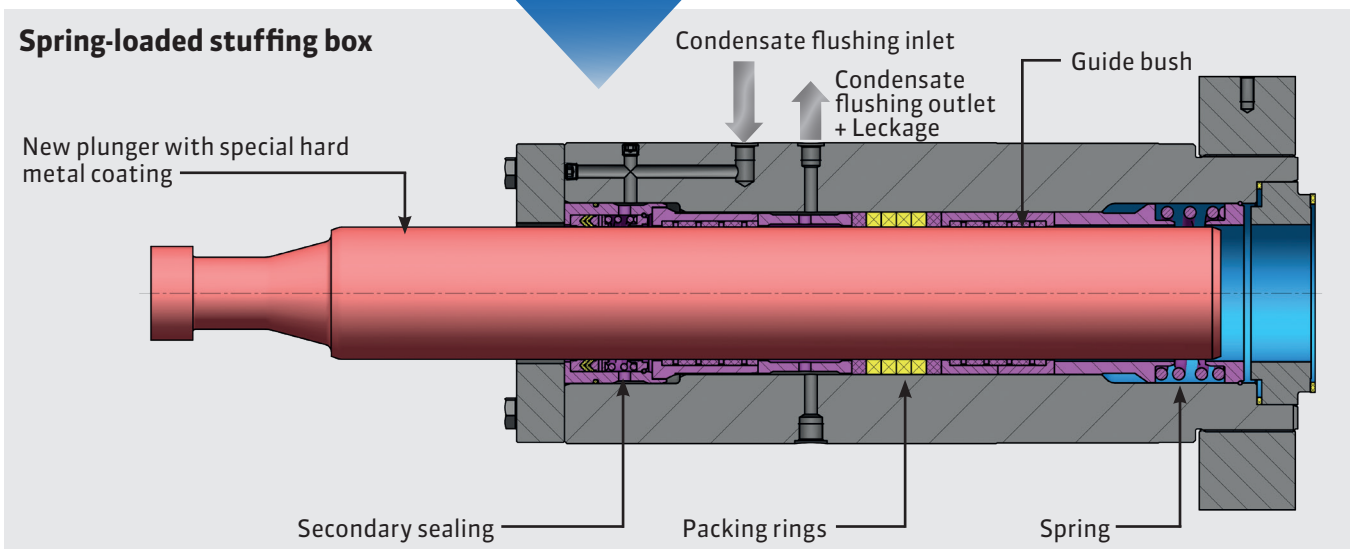
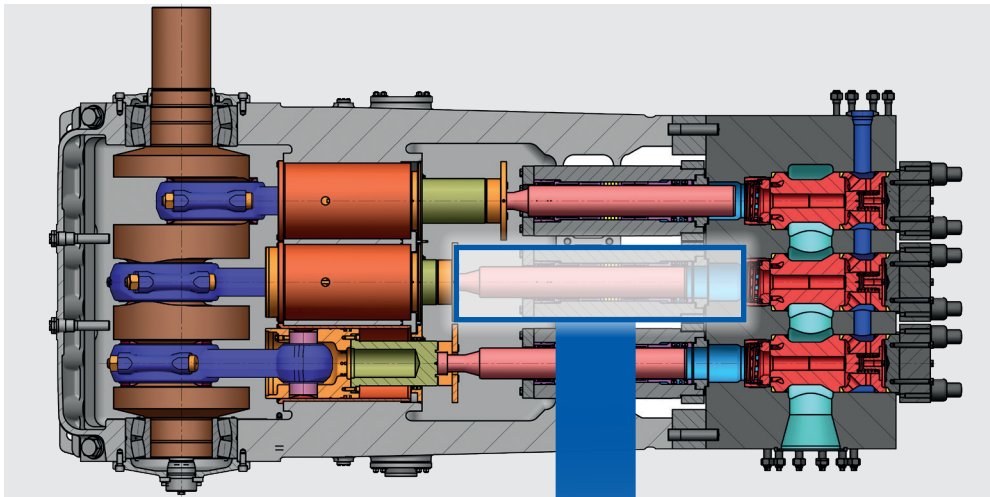

The advantages at a glance:

- **Optimal pretension of the packing rings:**
A defined spring in the front area takes care about it
- **Optimized ease of service:**
Adjustment of the gland nut is completely eliminated, during operation
- **Special hard metal coated plungers:**
The special hard coating, together with special packing rings and guide-bush arrangement makes the plunger highly resistant against wear and tear
- **Improved Lifetime:**
Under optimized conditions we reached already more than 30 months life time
- **Protection of the environment:**
Due to improved secondary seal system, the NH₃ leakage into the atmosphere is reduced to a minimum
- **Simple installation:**
The installation is usually possible without further modification of the pump