

Vario Jet

State-of-the-art hydrodemolition of concrete

The URACA Vario Jet stands for economical, efficient and careful large-surface demolition of concrete. The hydrodemolition technique has clear advantages comparing to other methods (surface milling, pneumatic hammer, flame jetting):

- No formation of microcracks in the concrete.
- No damage to the reinforcement.
- Complete rust removal on reinforcement.
- Good environmental compatibility.
- Selective demolition through »natural intelligence« of water jet.

Flexibility

Optimum surface performance and variable cutting technology through user-defined parameters:

- 360° swivel-mounted and rotatable cutting unit.
- User programmable oscillating pendulum movement of lance nozzle.
- User programmable jet angle.
- User programmable feed modulus/rate, switch or continual mode.
- User programmable cutting width.
- User programmable speed.

Technical features

- Automotive/self-propelled 4-wheel electric vehicle with 2 steerable and 2 powered/driven wheels
- Programmable controls for cutting data and digital display for settings.
- Remote control for easy positioning.
- High performance and low maintenance electrohydraulic drive system.
- Effective spray guard for cutting unit.
- Wide range of nozzles available: single nozzles, rotating cleaning nozzles RWD, rotating cutting nozzles RAD etc.



Concrete resurfacing and demolition with the URACA Vario Jet. The impressive demolition depth in hard concrete and the careful and efficient exposure of the reinforcement speaks for itself.



NEU

Vario Jet details

URACA

Vario Jet		H 30	T 360
Power rating	kW	5,5	5,5
Length	mm	2600	2800
Width (without cutting unit)	mm	1500	1500
Height	mm	1550	2100
Width of cutting unit	mm	1800	1800
Cutting width	mm	2000	2000
Swivel range of cutting unit	°	15	± 180
Working range left/right	mm	400	970
Vertical movement	mm	400	2500
Weight	kg	1200	1600

Dimensions and working range Vario Jet T 360

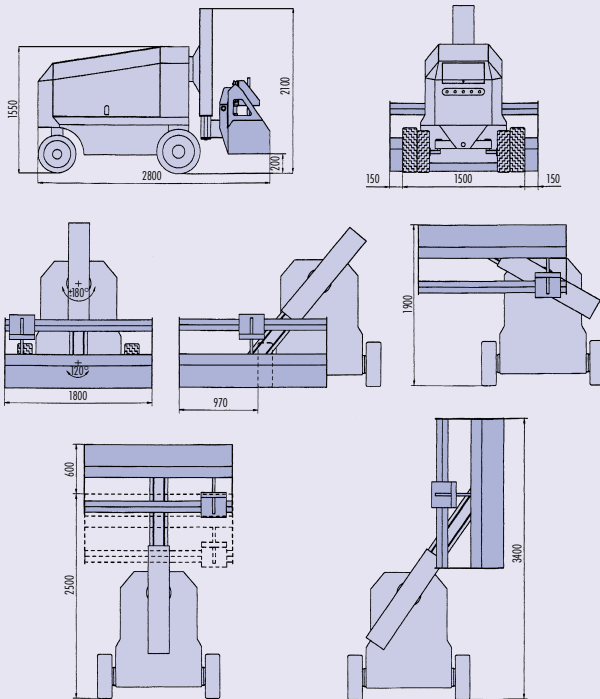

Control panel with display.



Remote control unit.



Hose guidance.



Tool holding fixture.

URACA Pumpenfabrik GmbH & Co. KG
 Sirchinger Straße 15
 D-72574 Bad Urach, Germany
 Phone +49 (71 25) 133-0
 Fax +49 (71 25) 133-202
 info@uraca.de
 www.uraca.de

Certified acc. to:

- DIN EN ISO 9001: 2000 by LRQA
- VGB KTA 1401
- Gost

