

# KD 716

# URACA

## Stuffing Box Change

The stuffing box area of the KD 716 pump blocks has been redesigned in order to provide easier maintenance for the plunger seal.

In the picture at the top the previous version is shown (available until approx. mid-2005); in the middle picture the redesigned version. The advantage of the new stuffing box version is that adjusting work when starting up, especially after changing sleeves, will no longer be necessary, as the mounted compression spring provides a correct initial tension of the seal and so automatically compensates for any changes in seal length (e.g. due to swelling, wear and tear, etc.). In the course of redesigning, the secondary seal (items 8 to 12) was changed at the same time. This measure provides even better protection against water entering the power end due to a defect high-pressure sleeve seal. When replacing the pump block the previous pump block casing, item 1, top picture, is to be replaced by a new one, item 1, middle or bottom picture), an additional compression spring (item 3) is required if the internal parts of the stuffing box of the former version continue to be used.

This interim solution is shown in the bottom picture.

In this case it is necessary to ensure when assembling that the stuffing box nut (item 7) is only wound so far into the pump block that a projecting end of approx. 6 mm remains.

Adjustment work on the stuffing box nut is likewise no longer required (see above). The secondary seal, however, corresponds to the previous version.

This is why we recommend changing to the new version shown in the middle picture when you later replace the stuffing box nut. We will be happy to provide you with the necessary parts for this. Please note: Pump blocks and pump block casings in the former versions are no longer available.

URACA Pumpenfabrik GmbH & Co.KG  
Sirchinger Str. 15  
D-72574 Bad Urach, Germany  
Phone +49 7125 133-0  
Fax +49 7125 133-202  
info@uraca.de  
www.uraca.de

Certified according to:

- DIN EN ISO 9001:2000 by LRQA
- VGB KTA 1401
- AD2000 - HPO
- Others upon request

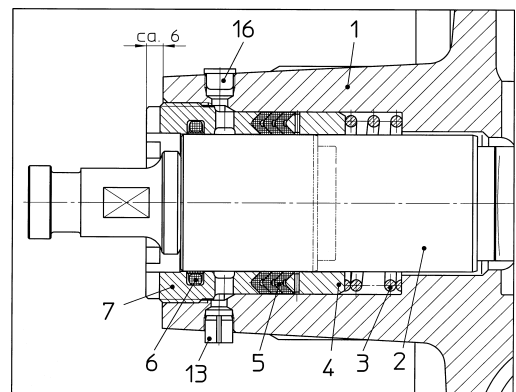
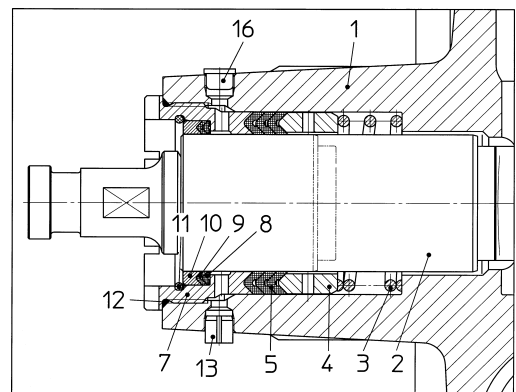
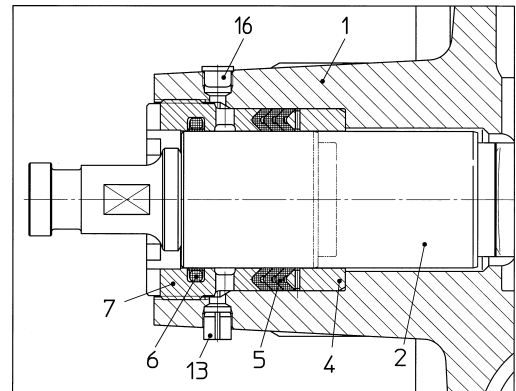

HIGH PRESSURE - STATE OF THE ART TECHNOLOGY - WORLDWIDE